

HDM64GS24_-4

Dimensional Drawing

240 X 64 Dots Graphic

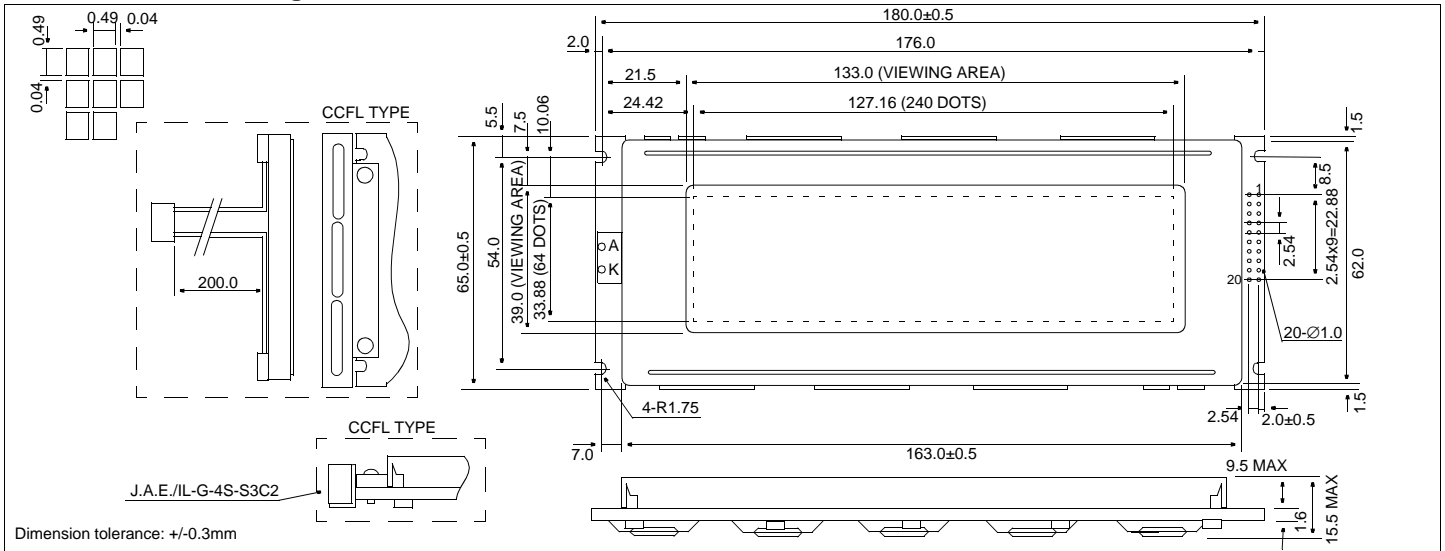

Features

Backlight.....EL, (White) LED or CCFL Optional
 Options.....FSTN (w/CCFL) / Gray STN / Yellow STN
 Normal/Extended Temperature
 Bottom / Top Viewing
 Built-in Controller.....Toshiba T6963C

Power Supply

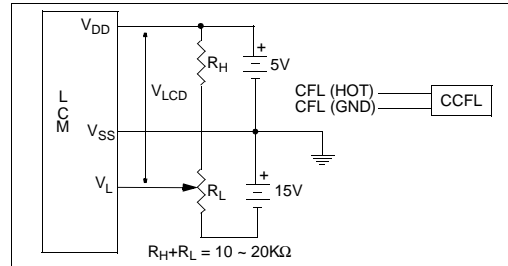

Physical Data

Module Size.....(LED) 180.0W x 65.0H x 15.5T mm
 (CCFL Backlight) 180.0W x 65.0H x 13.8T mm
 (EL or Reflective) 180.0W x 65.0H x 9.5T mm
 Viewing Area Size.....133.0W x 39.0H mm
 Dot Pitch.....0.53W x 0.53H mm
 Dot Size.....0.49W x 0.49H mm

Absolute Maximum Ratings

PARAMETER	SYMBOL	MIN	MAX	UNIT
SUPPLY VOLTAGE	$V_{DD}-V_{SS}$	0	7.0	V
POWER SUPPLY FOR LCD	V_O	-	-30.0	V
INPUT VOLTAGE	V_{IN}	0	7.0	V
OPERATING TEMPERATURE	T_{OP}	0	50	°C
STORAGE TEMPERATURE	T_{STG}	-20	70	°C

Electrical Characteristics (VDD=5.0±0.25V 25°C)

PARAMETER	SYM	CONDITION	MIN	TYP	MAX	UNIT
OPERATING VOLTAGE	V_{DD}	-	4.5	5.0	5.5	V
POWER SUPPLY FOR LCD	$V_{DD}-V_L$	-	12.6	13.0	13.4	V
INPUT HIGH VOLTAGE	V_{IH}	-	$V_{DD}-2.2$	-	V_{DD}	V
INPUT LOW VOLTAGE	V_{IL}	-	0	-	0.8	V
OUTPUT HIGH VOLTAGE	V_{OH}	$I_{OH}=0.2mA$	$V_{DD}-0.4$	-	V_{DD}	V
OUTPUT LOW VOLTAGE	V_{OL}	$I_{OL}=1.2mA$	0	-	0.4	V
POWER SUPPLY CURRENT	I_{DD}	$V_{DD}=5.0V$	-	13.0	-	mA
CCFL OPERATING VOLT.	V_{FL}	$I_{FL}=5mA$ rms	180	330	580	V rms
CCFL OPERATING CURR.	I_{FL}	$V_{FL}=330V$ rms	3.0	5.0	7.0	mArms
CCFL FREQUENCY	f_{FL}	-	20	35	-	kHz
LED OPERATING CURRENT (WHITE LED)	I_{LED}	-	-	220	-	mA
DRIVE METHOD			1/64 Duty			

Pin Connections

PIN NO.	SYMBOL	FUNCTION	
DATA CONNECTOR			
1	FG	Frame ground	
2	V_{SS}	0V	Ground
3	V_{DD}	5V	Power supply for logic
4	V_L	-8.6V	Operating voltage for LC
5	WR	L	Data write
6	RD	L	Data read
7	CE	L	Chip enable
8	CD	H/L	H= Command, L=Data
9	N/C	No connection	
10	RESET	L	Reset
11	DB0	H/L	Data bus
12	DB1	H/L	
13	DB2	H/L	
14	DB3	H/L	
15	DB4	H/L	
16	DB5	H/L	
17	DB6	H/L	
18	DB7	H/L	
19	FS	H/L	Font select
20	N/C	No connection	
CCFL CONNECTOR (IF USED)			
1	CFL HOT	-	Power supply for the CCFL
2	N/C	-	No connection
3	N/C	-	No connection
4	CFL GND	-	Power supply for the CCFL