

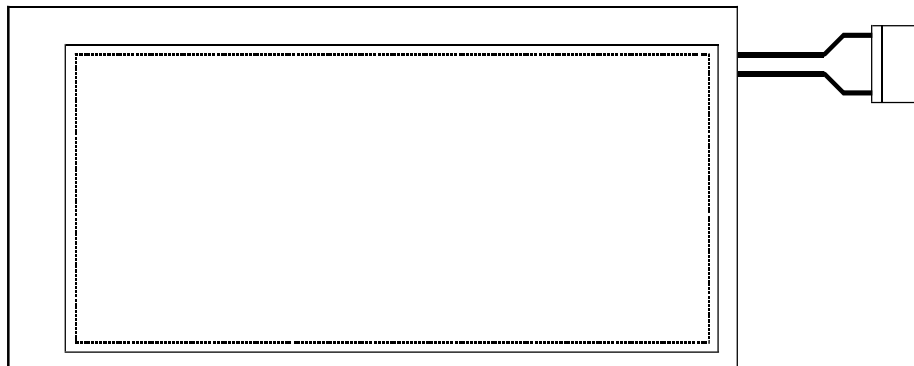

PRODUCT SPECIFICATION

HDM6424-C

640 x 240 COLOR GRAPHICS
LCD DISPLAY MODULE



HANTRONIX, INC. 10080 BUBB RD. CUPERTINO, CA 95014	Q.A.:	REV.:	HDM6424-C	SHEET 1 OF 18
	JB	1.0		DATE: 6/19/00

MECHANICAL DATA

(2) Module Size	173.0 (W)mm x 73.0 (H)mm x 6.7 (D)mm
(3) Dot Size	0.065 (W)mm x 0.225 (H)mm
(4) Dot Pitch	0.08 (W)mm x 0.24 (H)mm
(5) Number of Dots	640(W) x RGB x 240 (H)DOTS
(6) Duty	1/244
(7) LCD	F--STN:Color STN module Rear Polarizer:Color Transmissive Type
(8) Viewing Direction	6 O'clock
(9) Backlight	CCFL
(10) Controller	Excluded
(11) DC/DC Converter	Included
(12) Weight	123 g(approx.)

HANTRONIX, INC. 10080 BUBB RD. CUPERTINO, CA 95014	Q.A.:	REV.:	HDM6424-C	SHEET 2 OF 18
	JB	1.0		DATE: 6/19/00

ABSOLUTE MAXIMUM RATINGS

(1) ELECTRICAL ABSOLUTE RATINGS

VSS=0V

ITEM	SYMBOL	MIN	MAX	UNIT	COMMENT
Power Supply for Logic	VDD-VSS	0	6.0	V	Ta=25°C
Input Voltage	VI	-0.3	VDD+0.3	V	Ta=25°C
Vcon Voltage	Vcon	0	VDD	V	Ta=25°C
Static Electricity	-	-	-	-	Note 1

(2) ENVIRONMENTAL ABSOLUTE MAXIMUM RATINGS

ITEM	OPERATING		STORAGE	
	MIN.	MAX.	MIN.	MAX.
Ambient Temperature	0	50	-20	70
Humidity (Without Condensation)	Note 2,4		Note 3,4	
Vibration	Note 5			

Note 1 LCM should be grounded during handling LCM.

Note 2 Ta ≤ 50°C : 85%RH max

Ta > 50°C : Absolute humidity must be lower
than the humidity of 85%RH at 50°C

Note 3 Ta at -20°C will be < 48 hrs, at 70°C will be < 120 hrs

Note 4 Background color will change slightly depending on ambient temperature.
That phenomenon is reversible.

Note 5

Frequency	5 Hz~13.95 Hz	13.95 Hz~33 Hz	33 Hz~51 Hz	51 Hz~500 Hz
Vibration Level	-	2x9.8 m/s ²	-	5x9.8 m/s ²
Vibration Width	0.2 inch	-	0.036 inch	-
Vibration Direction	X/Y/Z			
Vibration Time	20 min/cycle X 3 directions			

HANTRONIX, INC. 10080 BUBB RD. CUPERTINO, CA 95014	Q.A.:	REV.:	HDM6424-C	SHEET 3 OF 18
	JB	1.0		DATE:

ELECTRICAL CHARACTERISTICS

ELECTRICAL CHARACTERISTICS OF LCM

VDD=3.3V±10%, Ta=25°C

ITEM	SYMBOL	CONDITION	MIN.	TYP.	MAX.	UNIT			
Logic Circuit Power Supply	VDD-VSS	Ta=25°C	3.0	3.3	3.6	V			
Input Voltage	VIH	H level	0.8VDD	-	VDD	V			
	VIL	L level	0	-	0.2VDD	V			
Contrast Adjust Voltage	Vcon-VSS	Duty=1/244 VDD=3.3V	Ta=0°C	0.8	-	-	V		
			Ta=25°C	-	1.95	-			
			Ta=50°C	-	-	2.8			
Supply Current for Logic	IDD	VDD-VSS=3.3V Ta=25°C PATTERN : ■ □ ■ □ ■ □ ■ □ □ ■ □ ■ □ ■ □ ■	-	60	150	mA			
LCM	Surface Luminance	L	VDD-VSS =3.3V Ta=25°C IL=1.5mArms	PATTERN: (Dots All On of White Color) □ □ □ □ □ □ □ □		-	77	-	cd/m ²
				PATTERN: (Dots All Off) ■ ■ ■ ■ ■ ■ ■ ■		-	2	-	

ELECTRICAL CHARACTERISTICS OF BACKLIGHT

Used lamp : Rating

PARAMETER	SYMBOL	MIN.	TYP.	MAX.	UNIT	REMARK
Lamp Voltage	V _L	-	468	-	Vrms	I _L = 1.5mArms
Lamp current	I _L	1.0	1.5	2.5	mArms	(*1)
Lamp power consumption	P _L	-	0.7	-	W	(*2)
Lamp frequency	F _L	40	50	60	KHz	
Lamp life time	L _L	10000	-	-	hrs	

(*1) It is recommended that I_L be not more than 2.5 mArms so that heat radiation of CCFT backlight may least affect the display quality .

(*2) Power consumption excluded inverter loss .

HANTRONIX, INC. 10080 BUBB RD. CUPERTINO, CA 95014	Q.A.:	REV.:	HDM6424-C	SHEET 5 OF 18
	JB	1.0		DATE:

OPTICAL CHARACTERISTICS

Optical Char. of Normal Temp. Mode

AT V_{OP}

ITEM MODE		Cr(Contrast Ratio)						θ (Viewing Angle)		ϕ (Viewing Angle)	
		0 $\text{ }^{\circ}\text{C}$		25 $\text{ }^{\circ}\text{C}$		50 $\text{ }^{\circ}\text{C}$		25 $\text{ }^{\circ}\text{C}$		25 $\text{ }^{\circ}\text{C}$	
		MIN.	TYP.	MIN.	TYP.	MIN.	TYP.	MIN.	TYP.	MIN.	TYP.
T	M	-	43	-	22	-	5.1	-	110	-	± 54
T	MC	-	51	-	24	-	5.3	-	110	-	± 54
note		NOTE 6						NOTE 5			

note:

T: TRANSMISSIVE

M: FOR 6 O'CLOCK COLOR STN MODULE

MC: FOR 6 O'CLOCK COLOR STN MODULE,POLARIZER WITH ANTI-GLARE

AT $\phi=0^{\circ}$ $\theta=0^{\circ}$

ITEM	SYMBOL	CONDITION	MIN.	TYP.	MAX.	UNIT	NOTE
Response Time (rise)	Tr	0 $\text{ }^{\circ}\text{C}$	-	660	770	ms	NOTE 2
		25 $\text{ }^{\circ}\text{C}$	-	240	270		
		50 $\text{ }^{\circ}\text{C}$	-	90	100		
Response Time (fall)	Tf	0 $\text{ }^{\circ}\text{C}$	-	240	250	ms	NOTE 2
		25 $\text{ }^{\circ}\text{C}$	-	80	90		
		50 $\text{ }^{\circ}\text{C}$	-	60	70		

HANTRONIX, INC.
10080 BUBB RD.
CUPERTINO, CA 95014

Q.A.:

JB

REV.:

1.0

HDM6424-C

SHEET 6 OF 18

DATE:

6/19/00

Color of CIE Coordinate

Ta = 25°C

ITEM	SYMBOL	CONDITION	VALUE	NOTE	
Color of CIE Coordinate	Red	X	φ=0° , θ=0°	0.482	Note*
		Y		0.354	
	Green	X	φ=0° , θ=0°	0.292	
		Y		0.530	
	Blue	X	φ=0° , θ=0°	0.158	
		Y		0.165	
	White	X	φ=0° , θ=0°	0.279	
		Y		0.349	

Note* CIE chromaticity diagram shown on Fig.1

Tolerance : ±0.05

Fig.1

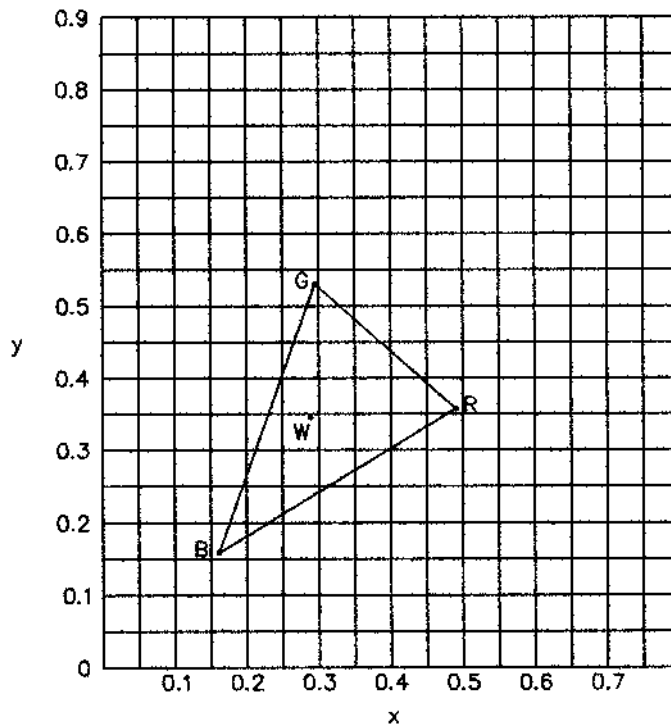

HANTRONIX, INC. 10080 BUBB RD. CUPERTINO, CA 95014	Q.A.:	REV.:	HDM6424-C	SHEET 7 OF 18
	JB	1.0		DATE:

(NOTE 1)

Definition of Operation Voltage(Vop)

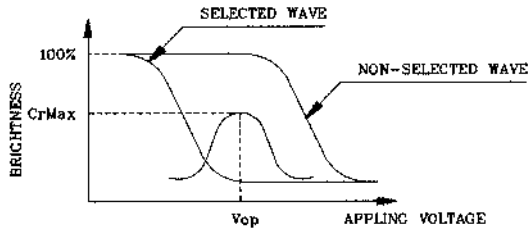

(positive type)

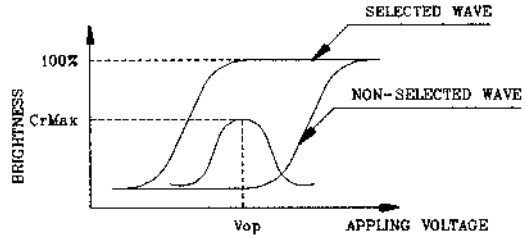

(negative type)

*Conditions

Viewing Angle : 0
 Frame Frequency : 70Hz
 Applying Waveform : 1/N duty 1/a bias

(NOTE 2)

Definition of Response Time(Tr,Tf)

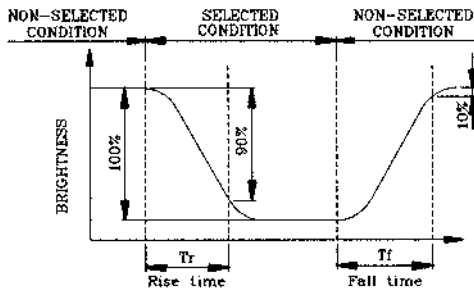

(positive type)

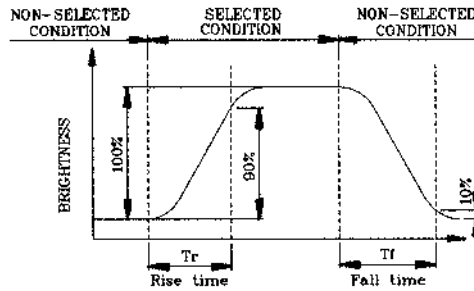

(negative type)

*Conditions

Operating Voltage : Vop
 Viewing Angle (θ,θ) : (0,0)
 Frame Frequency : 70Hz
 Applying Waveform : 1/N duty 1/a bias

(NOTE 3)

Description of Measuring Equipment and Driving Waveforms

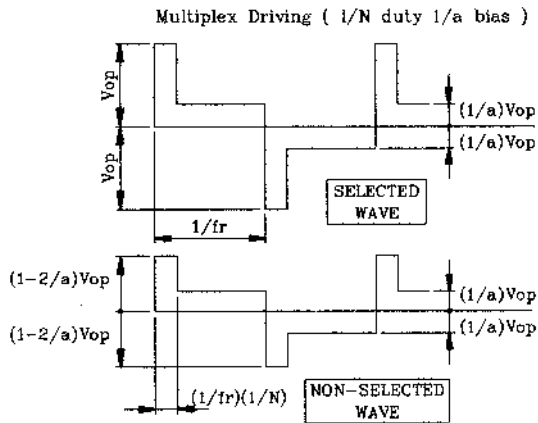
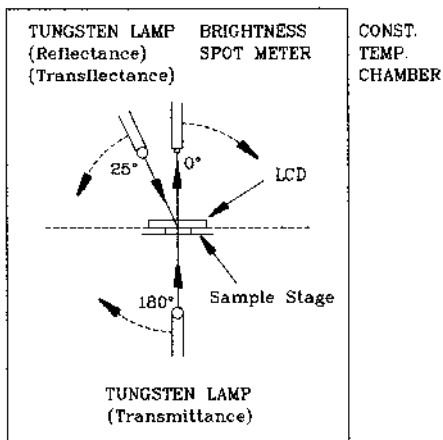

(NOTE 4)

Definition of Viewing Direction

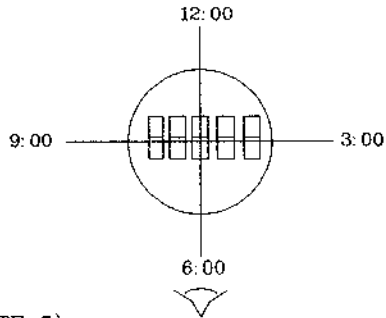

(NOTE 5)

Definition of Viewing Angle

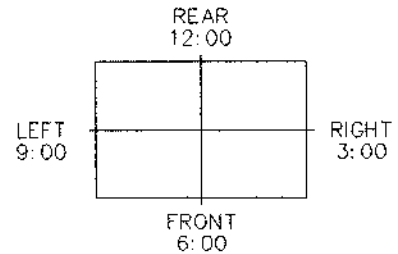
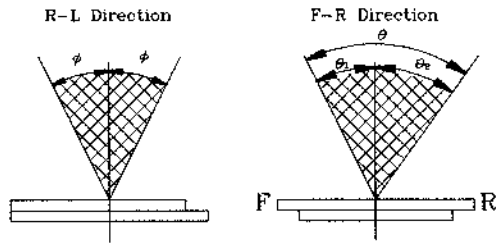

*For This Product
The Viewing Direction Is 6 O'clock
So $\theta_1 > \theta_2$

$$\theta = \theta_1 + \theta_2$$

*Conditions

Operating Voltage : V_{op}
Frame Frequency : 70Hz
Applying Waveform : 1/N duty 1/a bias
Contrast Ratio : larger than 2

(NOTE 6)

Definition of Contrast Ratio (Cr)

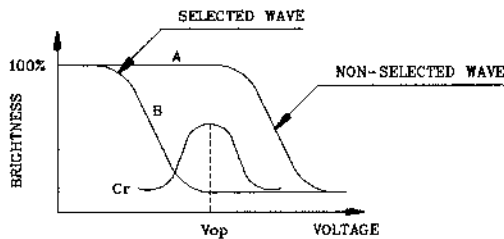

(positive type)

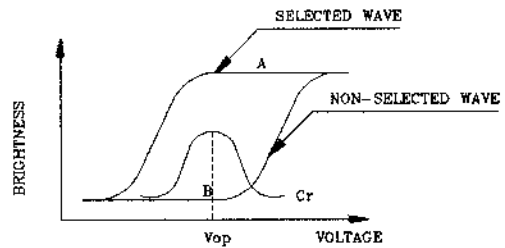

(negative type)

$$\text{Contrast Ratio : } Cr = A/B$$

*Conditions

Viewing Angle : 0
Frame Frequency : 70Hz
Applying Waveform : 1/N duty 1/a bias

HANTRONIX, INC.
10080 BUBB RD.
CUPERTINO, CA 95014

Q.A.:
JB

REV.:
1.0

HDM6424-C

SHEET 9 OF 18

DATE:
6/19/00

BLOCK DIAGRAM

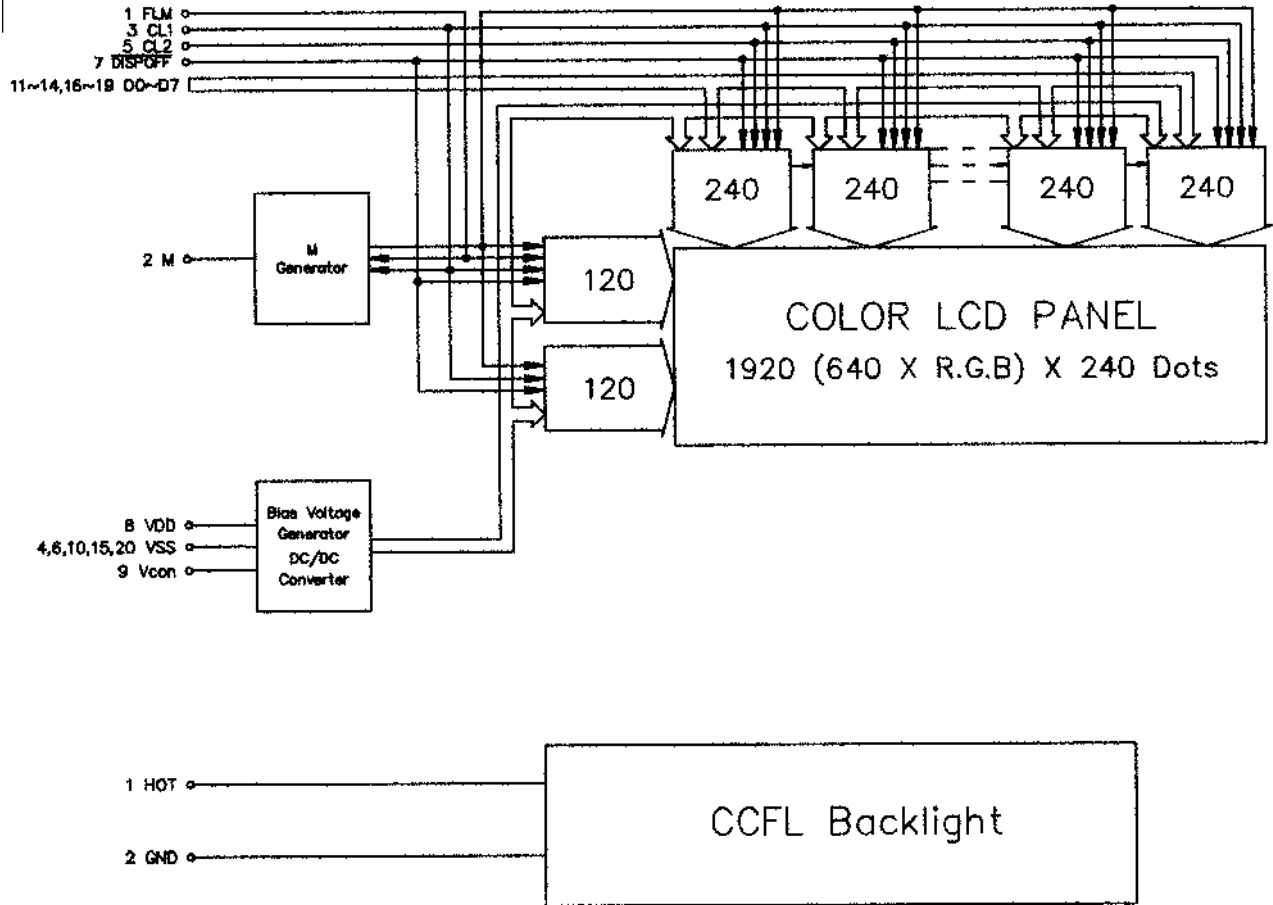

HANTRONIX, INC. 10080 BUBB RD. CUPERTINO, CA 95014	Q.A.:	REV.:	HDM6424-C	SHEET 10 OF 18
	JB	1.0		DATE: 6/19/00

INTERFACE PIN CONNECTION

LCD

Pin No.	Symbol	Level	Function
1	FLM	"H"	Scan start-up signal
2	M	-	Control signal for AC driving
3	CL1	"H" → "L"	Input data latch signal
4	VSS	-	GND
5	CL2	"H" → "L"	Shift clock for input data
6	VSS	-	GND
7	DISP	H(ON),L(OFF)	Display control signal
8	VDD	-	Power Supply for logic (+3.3V)
9	Vcon	-	Contrast adjustment voltage
10	VSS	-	GND
11	D0	H(ON),L(OFF)	Display Data signal
12	D1	H(ON),L(OFF)	Display Data signal
13	D2	H(ON),L(OFF)	Display Data signal
14	D3	H(ON),L(OFF)	Display Data signal
15	VSS	-	GND
16	D4	H(ON),L(OFF)	Display Data signal
17	D5	H(ON),L(OFF)	Display Data signal
18	D6	H(ON),L(OFF)	Display Data signal
19	D7	H(ON),L(OFF)	Display Data signal
20	VSS	-	GND

CN1 : FH12-20S-0.5SH(HIROSE)

MATING CABLE : FFC or FPC,N20,PITCH 0.5mm, WIDTH 10.5mm,THICKNESS 0.3mm

CCFL

PIN NO.	SYMBOL	LEVEL	FUNCTION
1	HV	-	High Voltage Line
2	GND	-	Ground Line

FLCN : HV-2S-C1(JAE)

MATING CONNECTOR : HV-2P-HF-E1400(JAE) or COMPATIBLE

HANTRONIX, INC. 10080 BUBB RD. CUPERTINO, CA 95014	Q.A.:	REV.:	HDM6424-C	SHEET 11 OF 18
	JB	1.0		DATE: 6/19/00

POWER SUPPLY

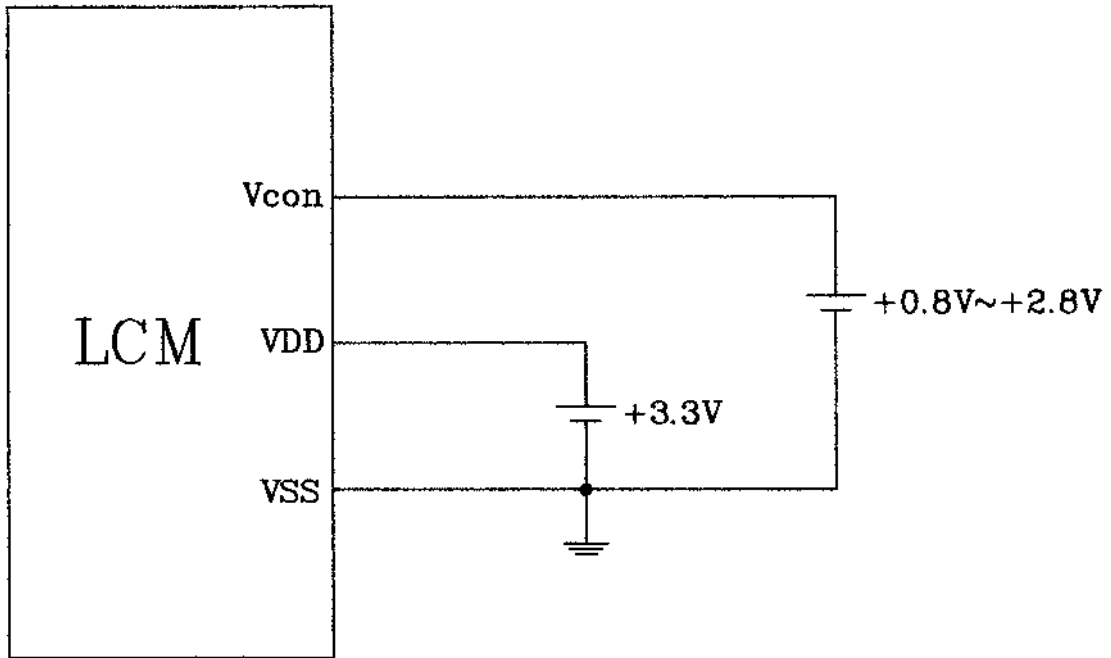

HANTRONIX, INC. 10080 BUBB RD. CUPERTINO, CA 95014	Q.A.:	REV.:	HDM6424-C	SHEET 12 OF 18
	JB	1.0		DATE: 6/19/00

TIMING CHARACTERISTICS

INTERFACE TIMING

VDD=5.0V ± 10%

Parameter	SYMBOL	MIN.	MAX.	UNIT
CLOCK PULSE CYCLE TIME	t_{wck}	50	—	ns
CLOCK PULSE HIGH LEVEL WIDTH	t_{wckH}	15	—	ns
CLOCK PULSE LOW LEVEL WIDTH	t_{wckL}	15	—	ns
LATCH PULSE HIGH LEVEL WIDTH	t_{wLPH}	20	—	ns
CL2→CL1 RISE TIME	t_{LD}	0	—	ns
CL2→CL1 FALL TIME	t_{SL}	25	—	ns
CL1→CL2 RISE TIME	t_{LS}	25	—	ns
CL1→CL2 FALL TIME	t_{LH}	25	—	ns
CLOCK PULSE RISE/FALL TIME	t_r, t_f	—	30	ns
DATA SETUP TIME	t_{DS}	10	—	ns
DATA HOLD TIME	t_{DH}	10	—	ns
FLM SETUP TIME	t_{SU}	100	—	ns
FLM HOLD TIME	t_H	30	—	ns

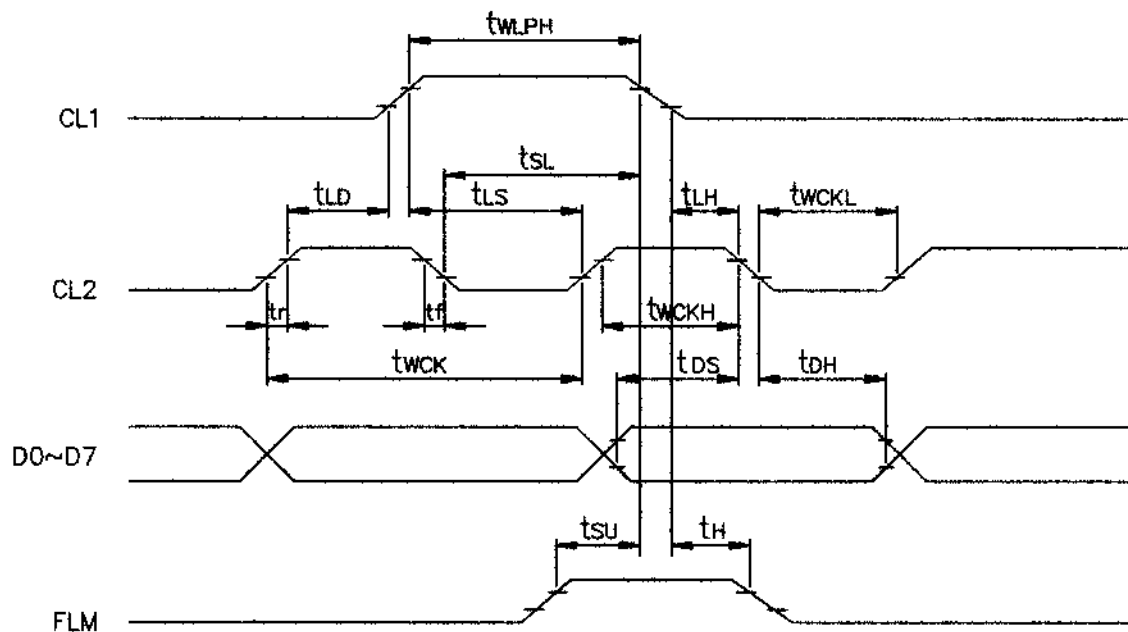

HANTRONIX, INC.
10080 BUBB RD.
CUPERTINO, CA 95014

Q.A.:
JB

REV.:
1.0

HDM6424-C

SHEET 13 OF 18

DATE:
6/19/00

TIMING CHART

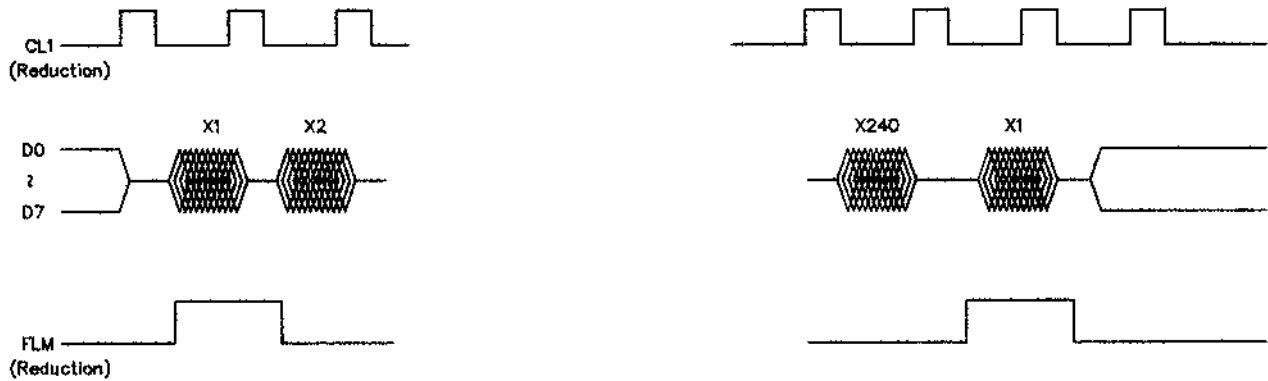
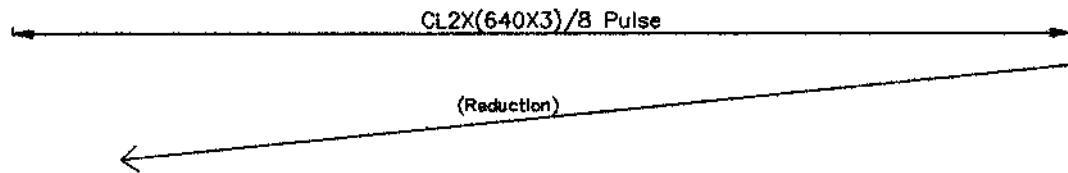
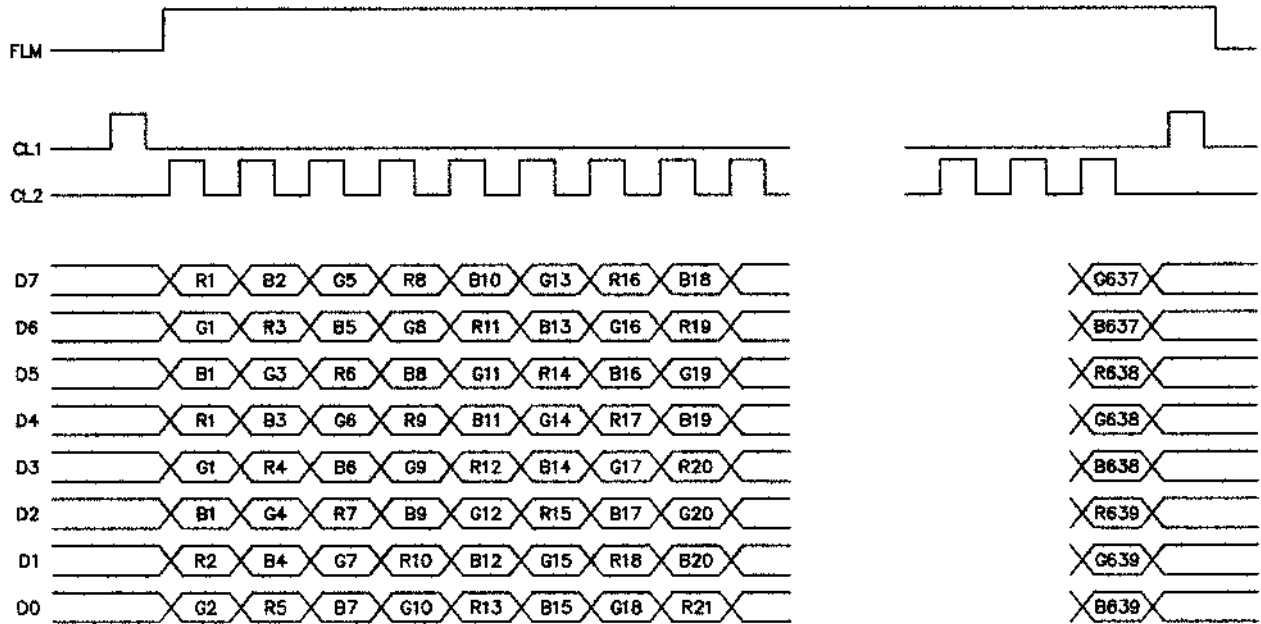

HANTRONIX, INC.
10080 BUBB RD.
CUPERTINO, CA 95014

Q.A.:
JB

REV.:
1.0

HDM6424-C

SHEET 14 OF 18

DATE:
6/19/00

POWER ON/OFF TIMING

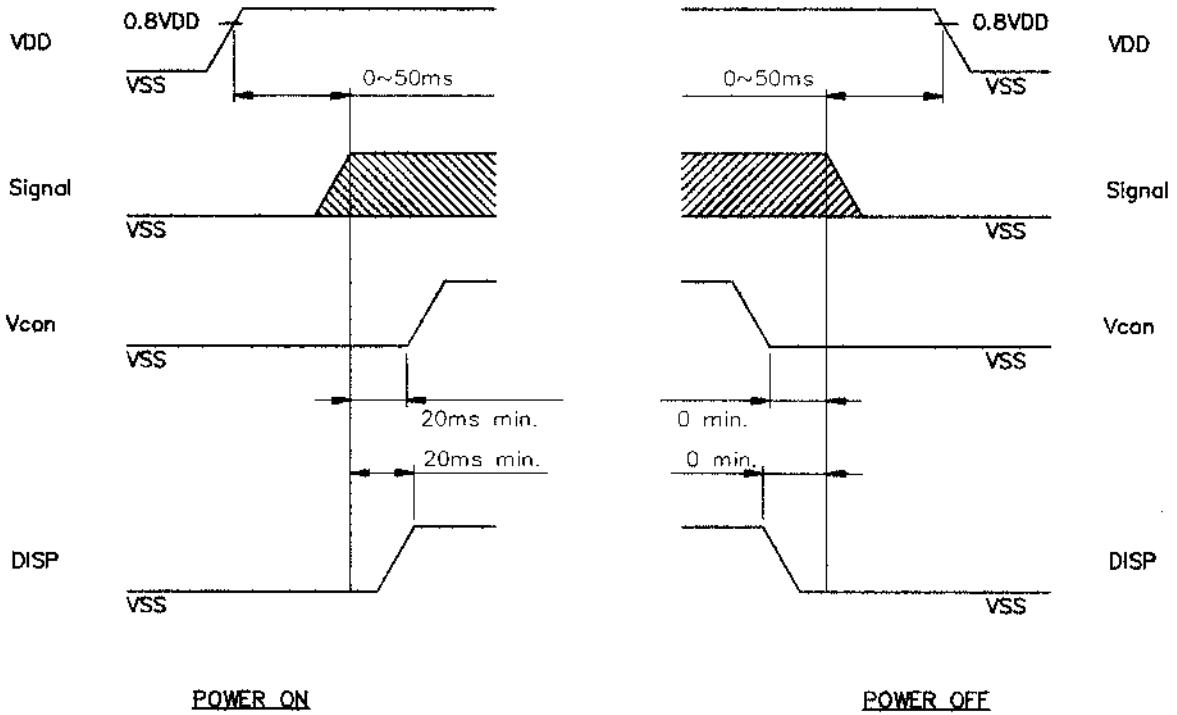

The missing pixels may occur when the LCM is driven beyond above power interface timing sequence.

HANTRONIX, INC. 10080 BUBB RD. CUPERTINO, CA 95014	Q.A.:	REV.:	HDM6424-C	SHEET 15 OF 18
	JB	1.0		DATE:

DISPLAY PATTERN

	1	2	3	4	5	6	7	8
1	R0 D7	G0 D6	B0 D5	R1 D4	G1 D3	B1 D2	R2 D1	G2 D0
2	R0 D7	G0 D6	B0 D5	R1 D4	G1 D3	B1 D2	R2 D1	G2 D0

COLUMN

	1913	1914	1915	1916	1917	1918	1919	1920
	G637 D7	B637 D6	R638 D5	G638 D4	B638 D3	R639 D2	G639 D1	B639 D0
	G637 D7	B637 D6	R638 D5	G638 D4	B638 D3	R639 D2	G639 D1	B639 D0

ROW

239	R0 D7	G0 D6	B0 D5	R1 D4	G1 D3	B1 D2	R2 D1	G2 D0
240	R0 D7	G0 D6	B0 D5	R1 D4	G1 D3	B1 D2	R2 D1	G2 D0

	G637 D7	B637 D6	R638 D5	G638 D4	B638 D3	R639 D2	G639 D1	B639 D0
	G637 D7	B637 D6	R638 D5	G638 D4	B638 D3	R639 D2	G639 D1	B639 D0

HANTRONIX, INC.
10080 BUBB RD.
CUPERTINO, CA 95014

Q.A.:
JB

REV.:
1.0

HDM6424-C

SHEET 16 OF 18

DATE:
6/19/00

NOTE:

• SAFETY

- 1.If the LCD panel breaks, be careful not to get the liquid crystal to touch your skin.
- 2.If the liquid crystal touches your skin or clothes, please wash it off immediately by using soap and water.

• HANDLING

- 1.Avoid static electricity which can damage the CMOS LSI.
- 2.Do not remove the panel or frame from the module.
- 3.The polarizing plate of the display is very fragile. So, please handle it very carefully.
- 4.Do not wipe the polarizing plate with a dry cloth, as it may easily scratch the surface of plate.
- 5.Do not use ketonics solvent & Aromatic solvent, use with a soft cloth soaked with a cleaning naphtha solvent.

• STORAGE

- 1.Store the panel or module in a dark place where the temperature is $25^{\circ}\text{C}\pm 5^{\circ}\text{C}$ and the humidity is below 65% RH.
- 2.Do not place the module near organics solvents or corrosive gases.
- 3.Do not crush, shake, or jolt the module.

• TERMS OF WARRANT

- 1.Acceptance inspection period
The period is within one month after the arrival of contracted commodity at the buyer's factory site.
- 2.Applicable warrant period
The period is within twelve months since the date of shipping out under normal using and storage conditions.

• THE OPERATING LIFE TIME OF BACK LIGHT

CCFT : 10,000HR

HANTRONIX, INC. 10080 BUBB RD. CUPERTINO, CA 95014	Q.A.:	REV.:	HDM6424-C	SHEET 17 OF 18
	JB	1.0		DATE: 6/19/00

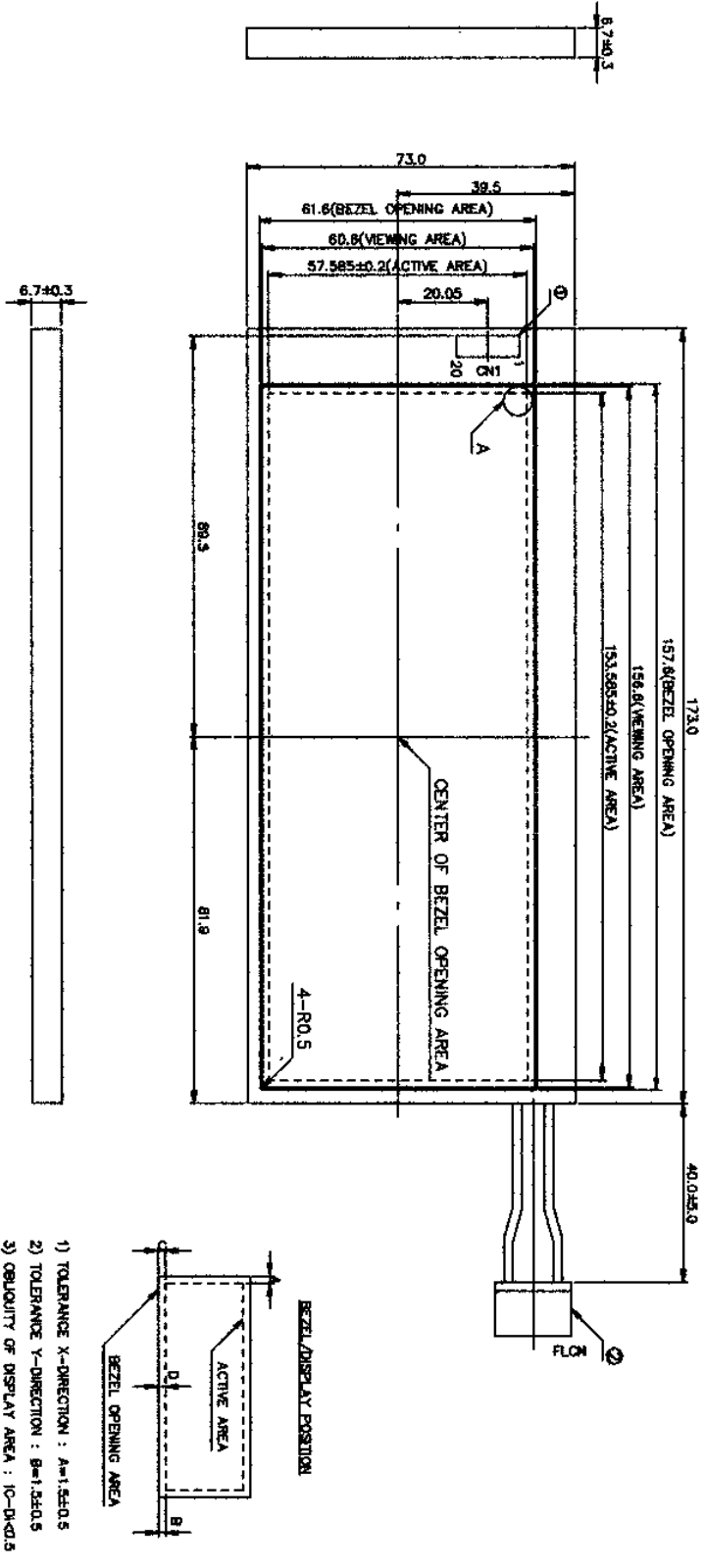

④ COFT CONNECTOR
 FLOM : HY-2S-CI(LAE)
 MATING CONNECTOR :
 HY-2P-1F-ET400(LAE) or COMPATIBLE

Pin No	Symbol
1	HOT
2	GND

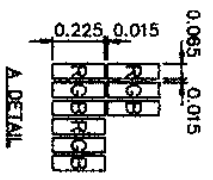

NOTE :

1. RESOLUTION : 640 X 3(R,G,B.) X 240 DOTS
2. TOLERANCE NO SPECIFIED : ±0.5 mm

④ INTERFACE CONNECTOR
 CNI : FH12-20S-0.35SH(W/ROSE)
 MATING CABLE : FTC or FTCN120, PITCH 0.5mm,
 WIDTH 10.5mm, THICKNESS 0.3mm

- 1) TOLERANCE X-DIRECTION : A=1.5±0.5
- 2) TOLERANCE Y-DIRECTION : B=1.2±0.5
- 3) OBSCURITY OF DISPLAY AREA : C=D=0.5

